

() , ()

*

(/ / : // :)

% % %

/ /

(/)

%

:

.(Yu, 2006)

.(Wong, J.Y., 2001)

.(Anon. 2003)

.(Raper, 2005)

(Shoop, (CI)

.1993)

.(Boon *et al.*, 2005)

ASAE EP542 FEB99

.(Boon *et al.*, 2005)

:

:

:

jmassah@ut.ac.ir :

*

1. Cone Index
2. Cone Penetrometer
3. Penetration Resistance.



(Anon., 2003)

ASAE S313.3 FEB04

(AISI 416, Stainless Steel)

St 37

M20

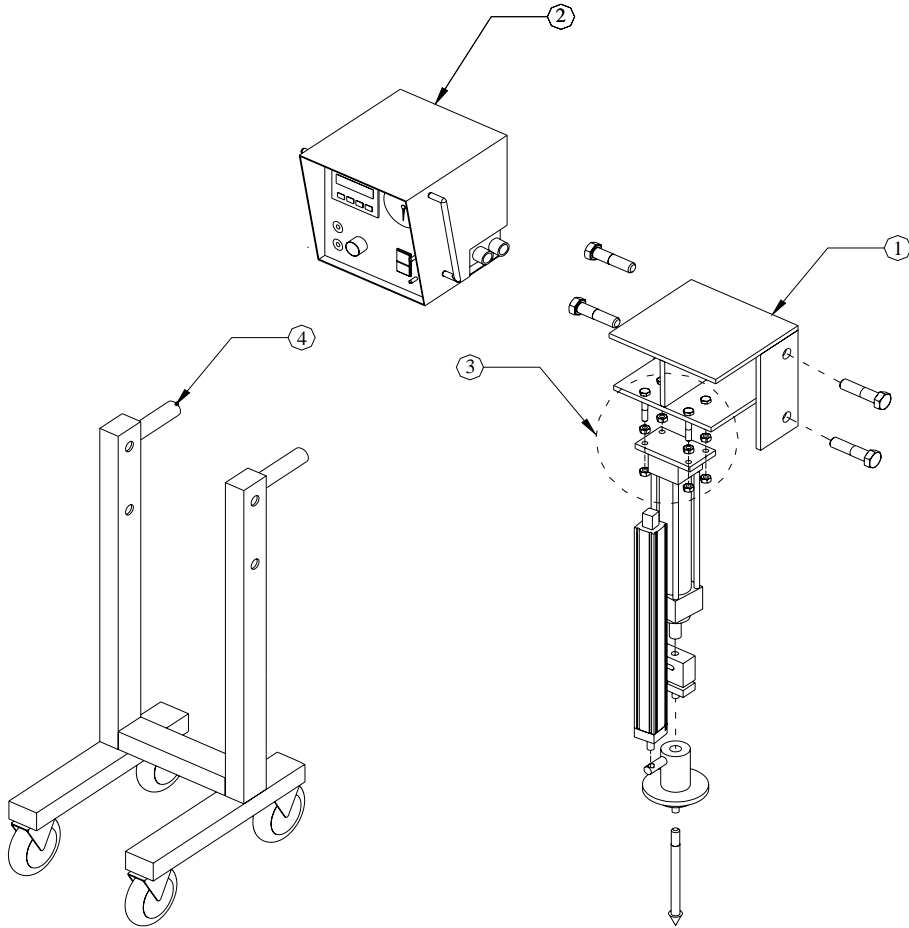

()

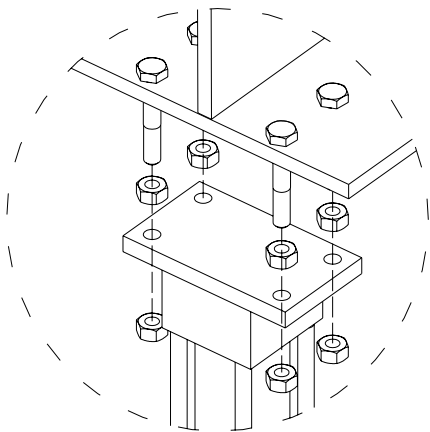

St37

S

-
- 1 . Interface
 - 2 . Load Cell

()

:

:

:

:

(MSP-01-H, Hystar, Taiwan)

()

(DSG-3C60-01-D24, Hystar, Taiwan)

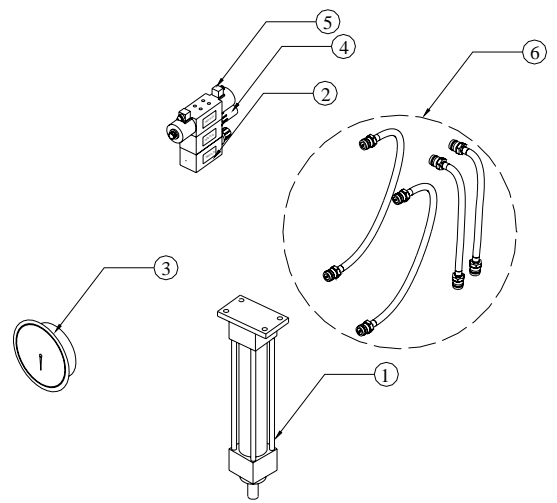

$\frac{3}{\lambda}$

()

(AHE01350A-3A-3, Taiyo, Japan)

(Wong, J. Y.,

2001)

(DBBP, Bongshin, Korea)

/

S

/

(MBP-01-H, Hystar, Taiwan)

RS232

(KTC 375, Hystar,

Taiwan)

Notepad

:RS232

RS232

USP



(CAWL2RG, Camos, Iran)

(V3515WL1, Fujitsu

CPU GHz 768 MB RAM

Siemens, German)

2.00

, ()

± / ± /

±

/ / /

/

± /

× ×

mat

(())
() ()
() ()

Excel

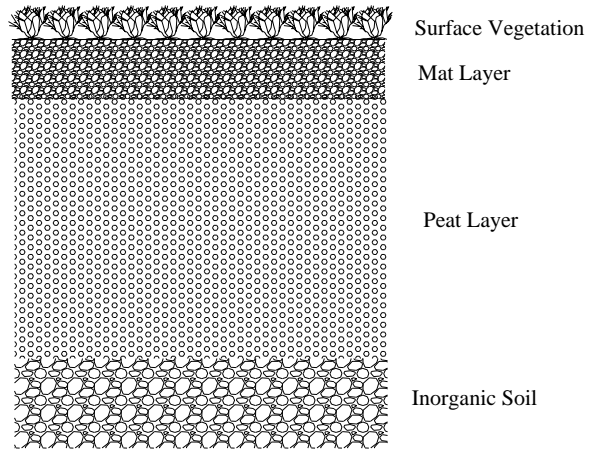

mat

peat

mat

(Wong, J.Y.,

.2001)

%

درصد رطوبت (%)

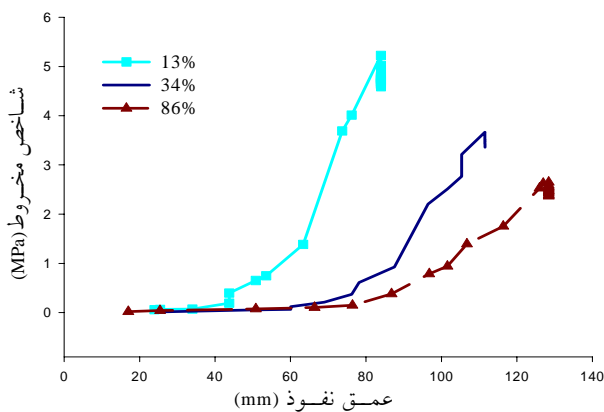
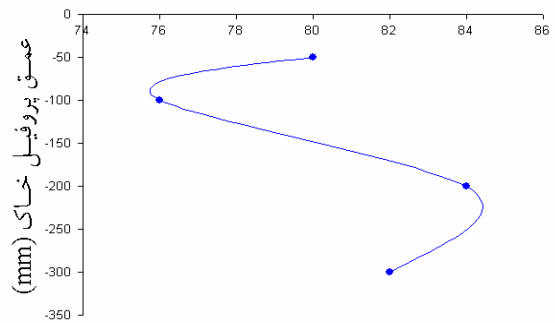

(Wong et al., 1979)

REFERENCES

- ASAE EP542 FEB99, (2003). *Procedures for Using and Reporting Data Obtained with the Soil Cone Penetrometer*. Available on line at <http://www.asae.org>: 1008-1011.
- ASAE S313.3 FEB04, (2003). *Soil Cone Penetrometer*. Available on line at <http://www.asae.org>: 858-860.
- Benoit, O. & Gotteland, Ph., (2005). Modelling of

Sinkage Tests in Tilled Soils for Mobility Study. *Soil & Tillage Research*, 80, 215-231.

- Boon, N.E., Yahya, A., Kheiralla, A.F., Wee, B.S. & Gew, S.K., (2005). A Tractor-Mounted, Automated Soil Penetrometer-Shearometer Unit for Mapping Soil Mechanical Properties. *Biosystems Engineering*, 90 (4), 381-396.

- Raper, R.L., (2005). Agricultural traffic impacts on soil. *Journal of Terramechanics* 42, 259–280.
- Shoop, S.A., (1993). Terrain Characterization for Trafficability. US Army Corps of Engineers. *CRREL Report* 93-6.
- Wong, J.Y., (2001). *Theory of Ground Vehicles*. 3rd Edition. New York, John Wiley.
- Wong, J.Y., Garber, M., Radforth, J.R. & Dowell, J.T., (1979). Characterization of the Mechanical Properties of Muskeg with Special Reference to Vehicle Mobility. *Journal of Terramechanics*, Vol. 16, No. 4, pp. 163 to 180.
- Yu, T., (2006). *The Tractive Performance of a Friction-based Prototype Track*. A Ph.D. Thesis, Faculty of Engineering, Built Environment and Information Technology University of Pretoria, South Africa.